

TECHNICAL SPECIFICATIONS

Engine

Engine Model	YANMAR 3TNV74F-SPFN
Number of Cylinders	3
Max. Torque/Speed	48~51.8/1800±100N·m/rpm
Displacement	1.267L

Hydraulic system

Max. Main Pump Flow	99L/min
Main Safety Valve Pressure	21.6MPa

Main Performance

Bucket Digging Force	15.2kN
Arm Digging Force	8.5kN
Max. Traction Force	13.5kN
Max. Walking Speed	3.9km/h
Min. Walking Speed	1.9km/h
Rotary Speed	9r/min
Gradeability	30°
Ground Pressure	32.04kPa

Oil Capacity

Fuel Tank	19L
Hydraulic Tank	15.4L
Engine Oil	3.4L



LOVOL HEAVY INDUSTRY GROUP CO.,LTD.

Address: No. 75, Huanghe East Road, Huangdao District, Qingdao City, Shandong Province, China.

Website: en.wlovol.com E-mail: lovol_overseas@global.lovol.com TEL: +86-532-86907190 Facebook: Cons Lovol

As manufacturer, LOVOL has right to constantly upgrade and improve our products without informing to customers. The pictures in literatures are for reference only, the detailed specifications are subject to real products.



Rated Power **10.9kW/2400rpm**

Operating Weight **2000kg**

Bucket Capacity **0.04 m³**

FR20F-u

EXCAVATOR



FLEXIBILITY

Tailless design - Turning radius 640mm

Boom side shift - Small space corner operation

Good passing ability

Chassis 1040mm; Closed cab, easy to pass 2m height limit

RELIABILITY

Boom bucket rod assembly explosion-proof valve

Prevent falling, oil spray

Load sensitive flow control

Allocate the appropriate flow according to the demand of the load

Large working range

Maximum excavation radius 3905 mm

Large bucket capacity

Bucket 0.04m³, High working efficiency

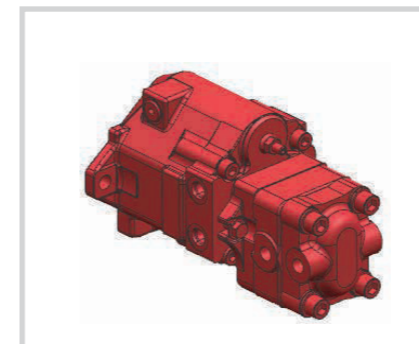
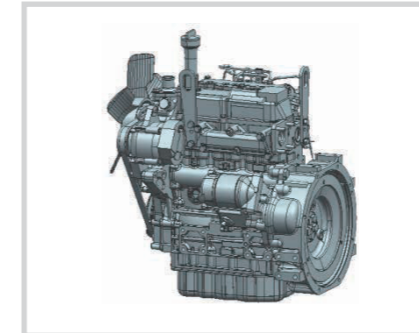
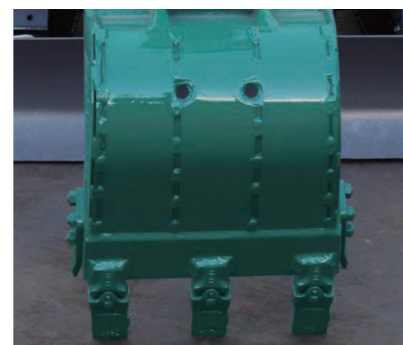

EFFICIENCY

Imported engine, high reliability, low noise design

Three pump automatic control, according to real-time operating conditions, adjust the power demand

LOVOL customized main control spool, micro-control more accurate

Using the leading cycloidal rotary motor, small size, light weight, large torque

Open inspection window, hood open at a large Angle, easy maintenance

Quick maintenance

Design multiple inspection Windows

COMFORT

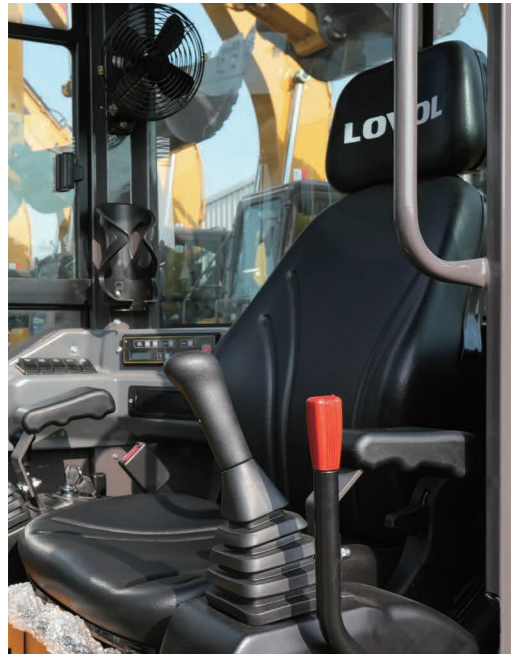

Yanmar engine

Low indoor and outdoor noise

Large radiator area

High heat dissipation performance

Humanization design

Increase the water cup holder, mobile phone case, increase the backrest height, headrest, backrest can be turned

Backrest extension, increase backrest height, backrest can be turned

Humanized design, water cup holder, mobile phone box

LED high brightness lights and increased shade protection

SAFETY



Cab meets certification requirements

FOPS/TOPS compliant cab, cockpit; Meet CE certified cab

Stable chassis operation

The chassis has a telescopic function (990-1280mm)

The front service window is hinged + locked to facilitate daily maintenance

12V power base, easy access to electricity, reliable and durable

Chassis retractable for increased passability and operational stability

Split removable driving canopy, height less than 1.5m, more passability

INCREASE YOUR PRODUCTIVITY AND PROFIT WITH LOVOL ATTACHMENTS

You can easily expand the performance of your machine by utilizing any of the variety of LOVOL Attachments. Each LOVOL Attachments is designed to fit the weight and horsepower of LOVOL Excavator for improved performance, safety, and stability.



Quick Coupler



Hydraulic Hammer



Hydraulic Rammer



Auger



Standard Bucket



TECHNICAL SPECIFICATIONS

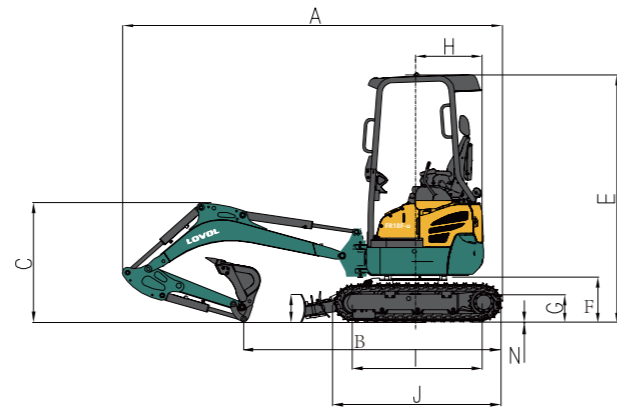
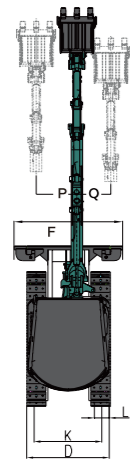

Working Range

Max. Digging Height	1	3540mm
Max. Dumping Height	2	2440mm
Max. Digging Depth	3	2310mm
Max. Vertical Digging Depth	4	1910mm
Max. Digging Radius	5	3905mm
Max. Ground Digging Radius	6	3845mm
Min. Turning Radius	7	1443mm
Dozer Blade Lifting Height	8	266mm
Dozer Blade Falling Height	9	176mm

Dimensions

Shipping Length	A	3575mm
Shipping Ground Length	B	/
Boom Height	C	1120mm
Shipping Width	D	990mm
Cab Height	E	2347mm
Ground Clearance of Counter Weight	F	438mm
Min. Ground Clearance	G	150mm
Tail Turning Radius	H	640mm
Wheel Tread	I	1230mm
Track Length	J	1593mm
Track Gauge	K	760/1050mm
Track Shoe Width	L	230mm

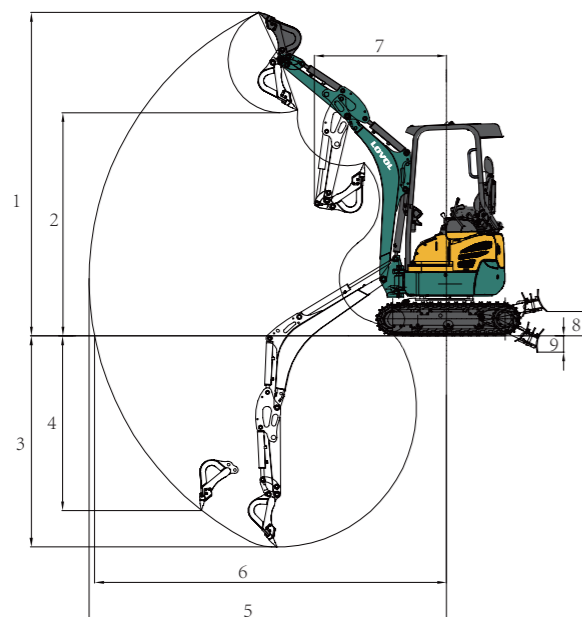

Other Specifications

Boom Length	1828mm
Arm Length	950mm
Track Section Number (each side)	37
Track Roller Number	3